

Maker

Iselin Joël

Inhalt

Wie bin ich dahin gekommen

Ich als Maker

Making im Kanton Zug

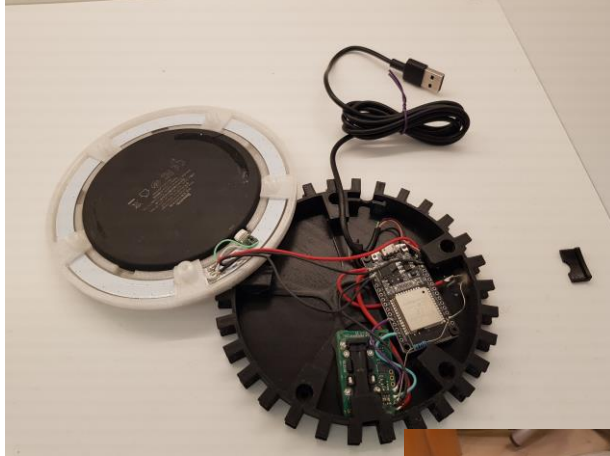
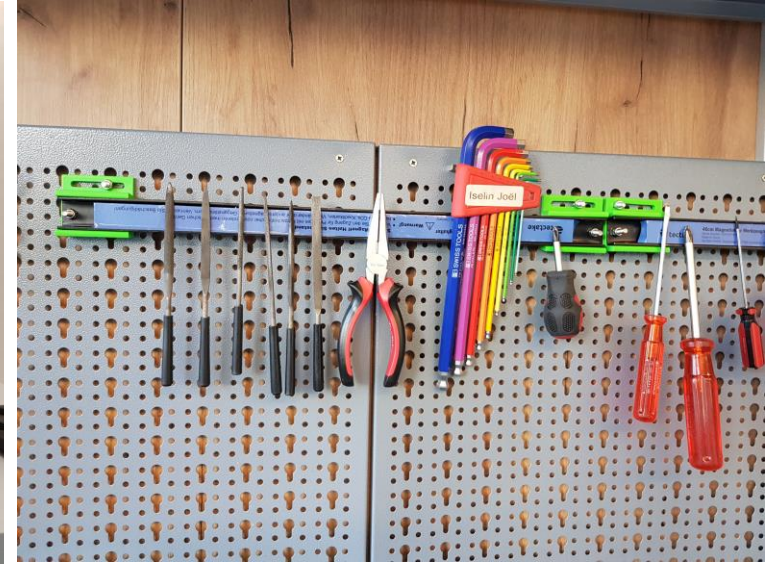

Wo steh ich aktuell

2013 - 2017

(Komax) Polymechaniker CNC

(Komax) Automatiker Schaltschrankbau

(Komax) Polymechaniker Montage

(Komax) Prüfmittelbau / Entwicklung

(Komax) Servicetechniker

2017 - 2023

(Komax) Elektroplanung

(Bibliotheca) SPS Entwickler

(GWF) Solutionarchitekt

(Ideall) Geschäftsführer

(Bibliothek Zug) Mitarbeiter Medienpädagogik

Individuelle Praktische Arbeit

Tornado

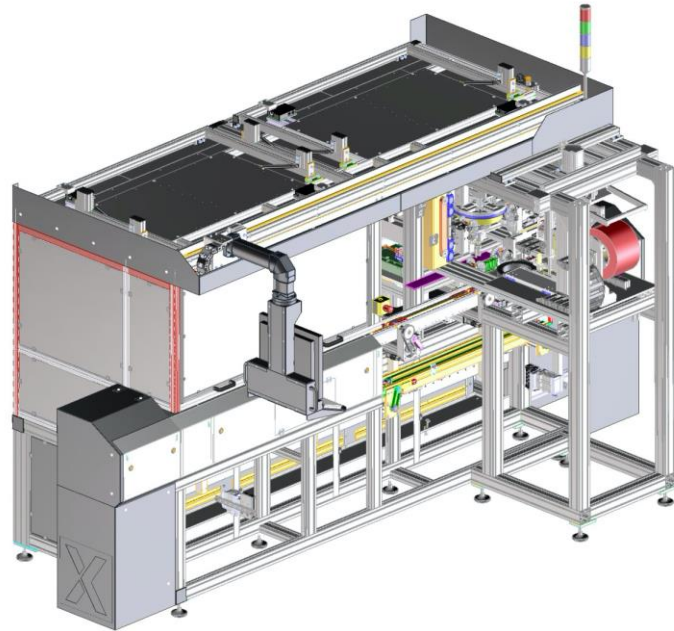

Prüfungskandidat: Joël Iselin
Lehrbetrieb: Komax AG
Kandidatennummer: 17
Abgabetermin: 18. April 2017
Fachvorgesetzter: Pascal Risi
Experten: Igor Lijak, Stefan Schraven



Elektroplanung

2018 - 2020

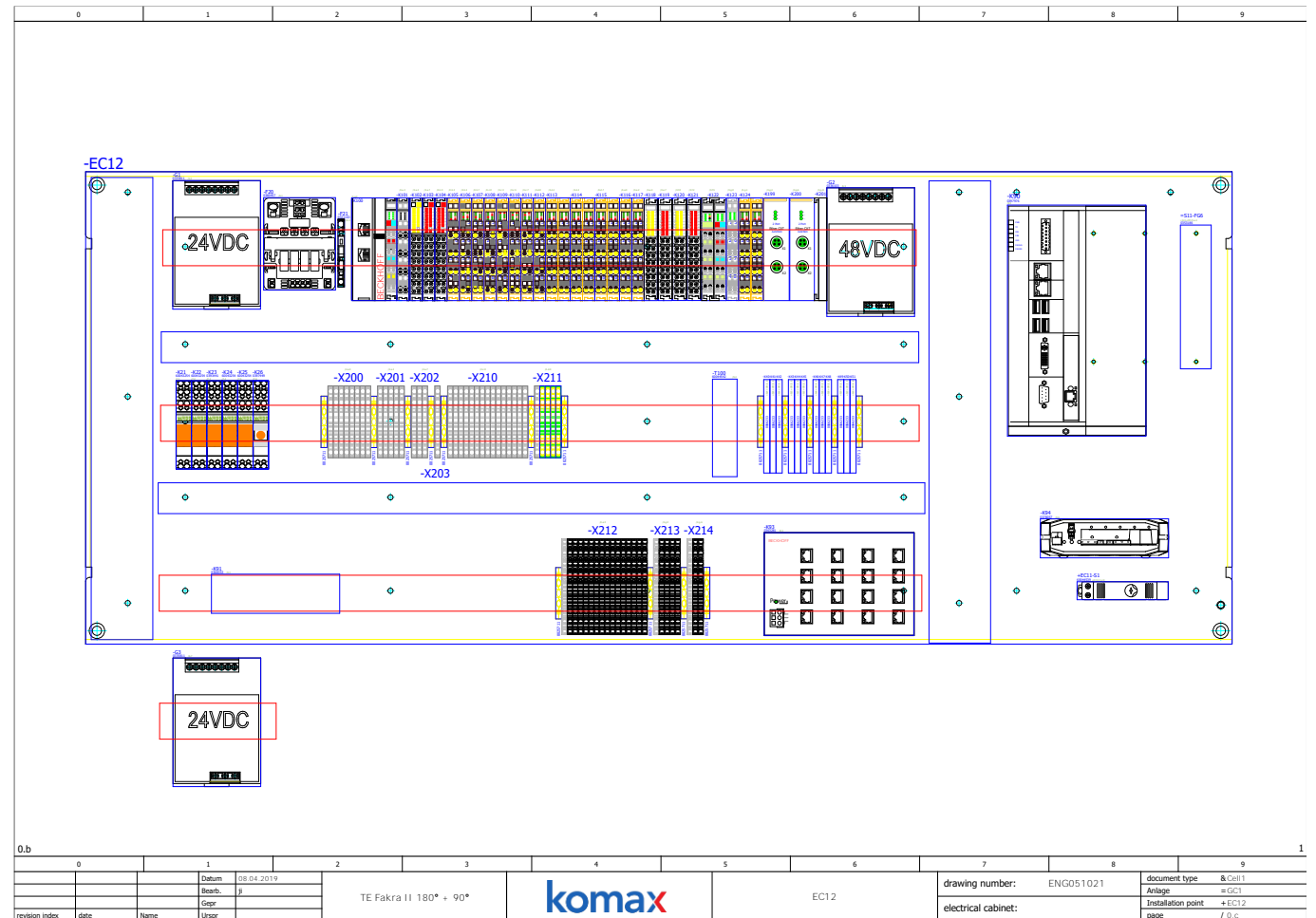
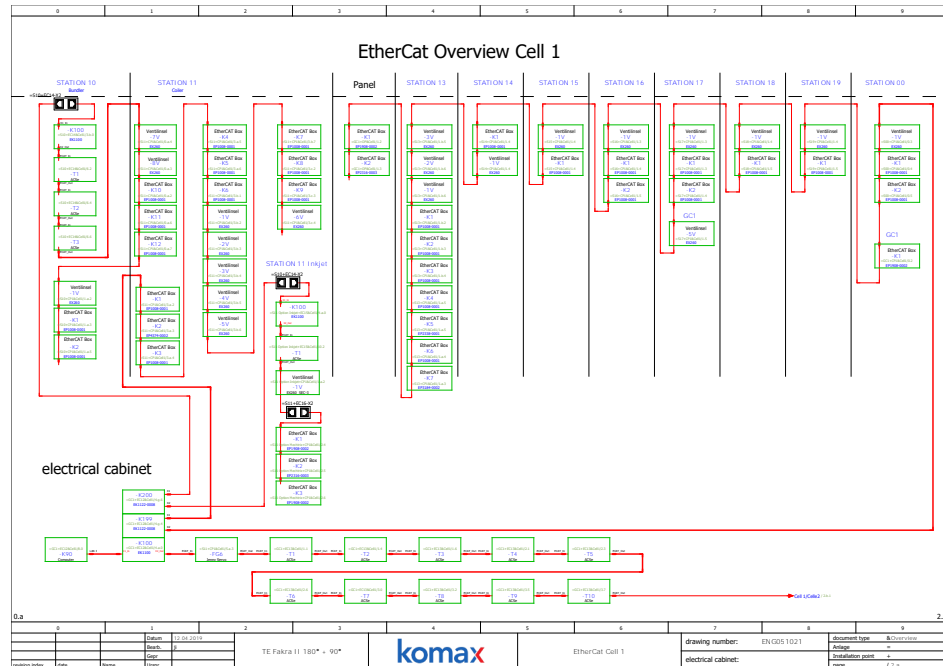



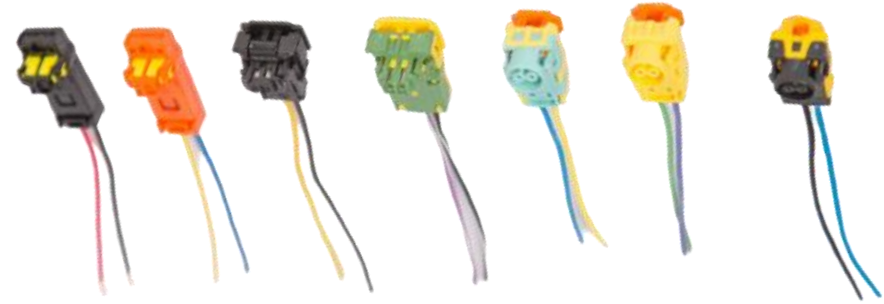

PLC Programmierer

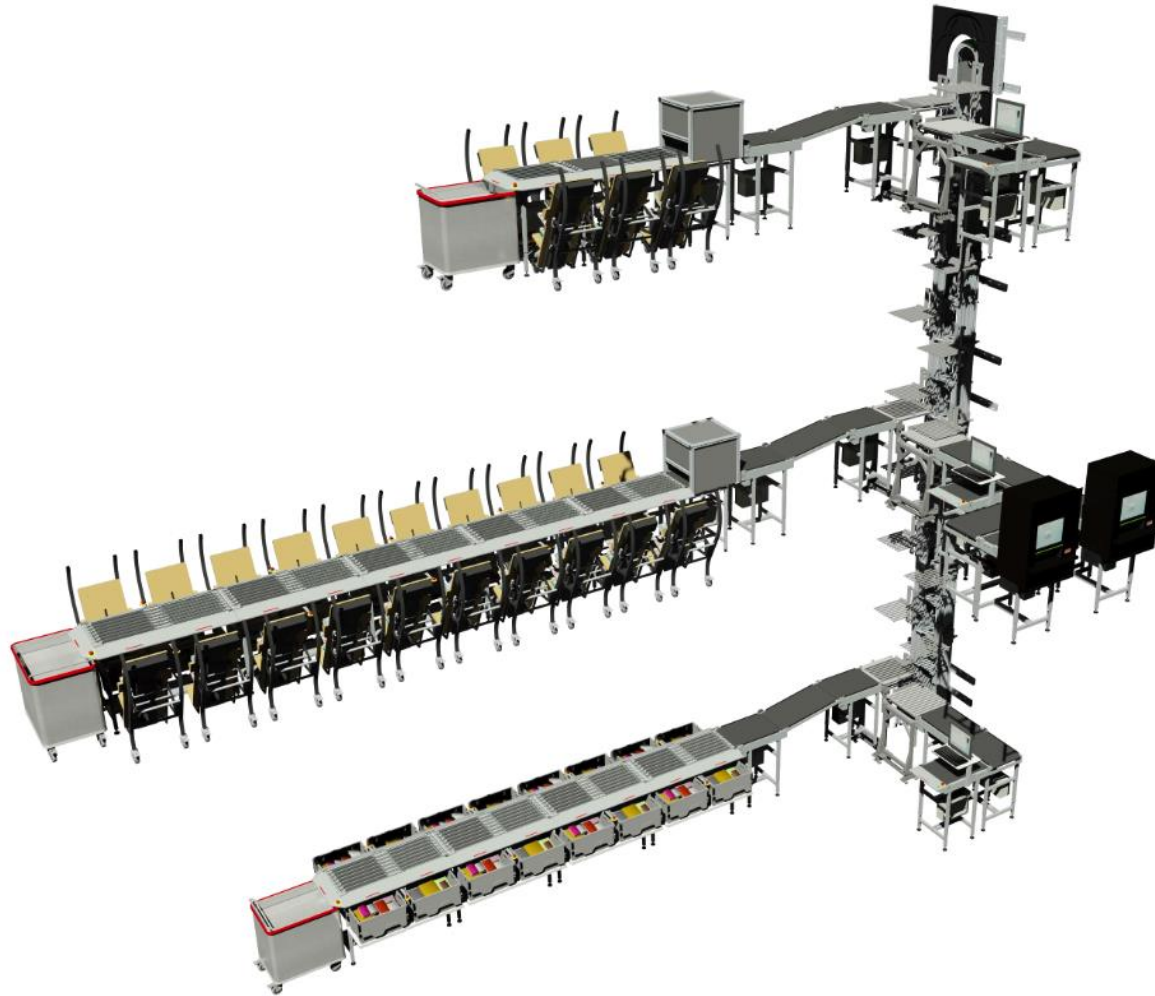

Möglicher Initiator

Welche Erfahrungen führten zu einer technischen Leidenschaft





Start im Atelier

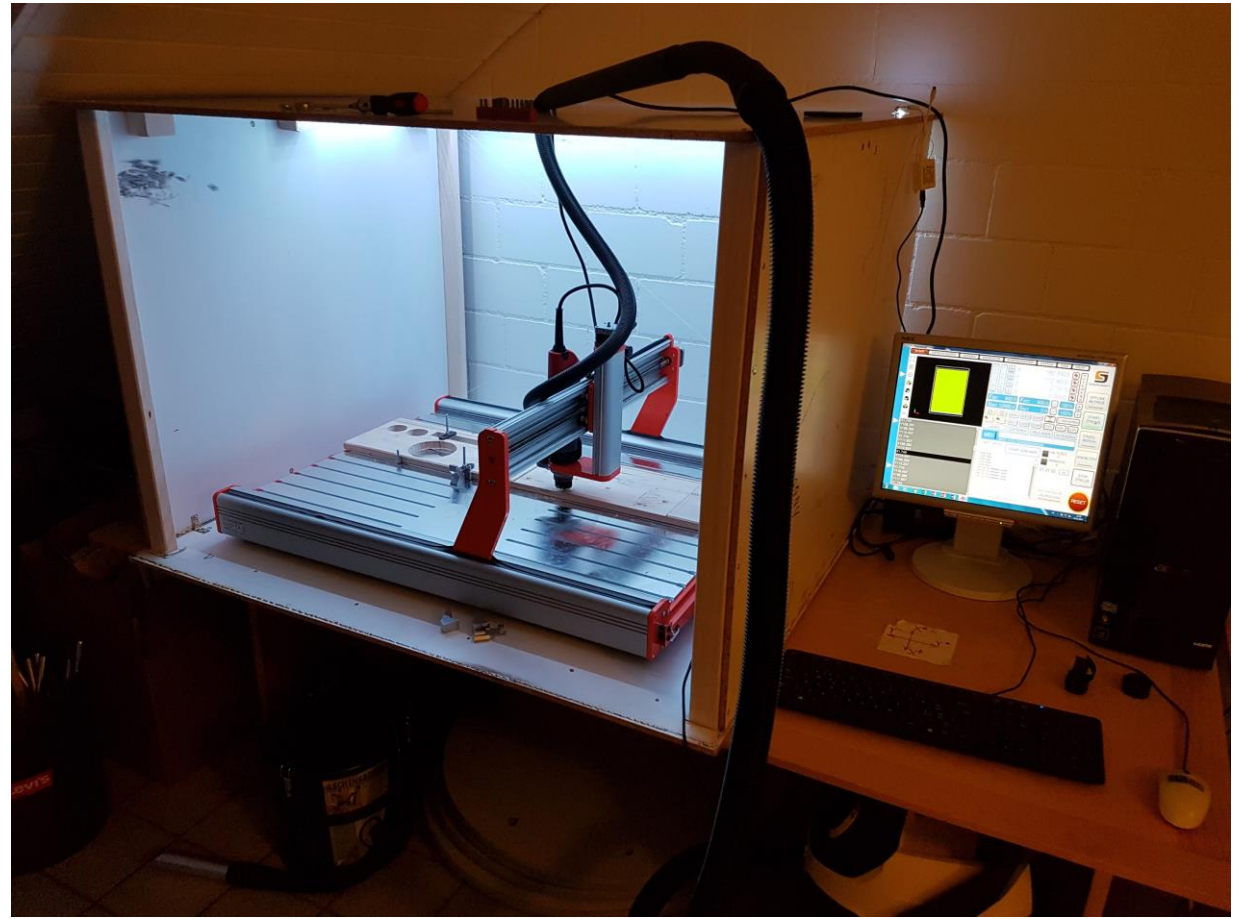

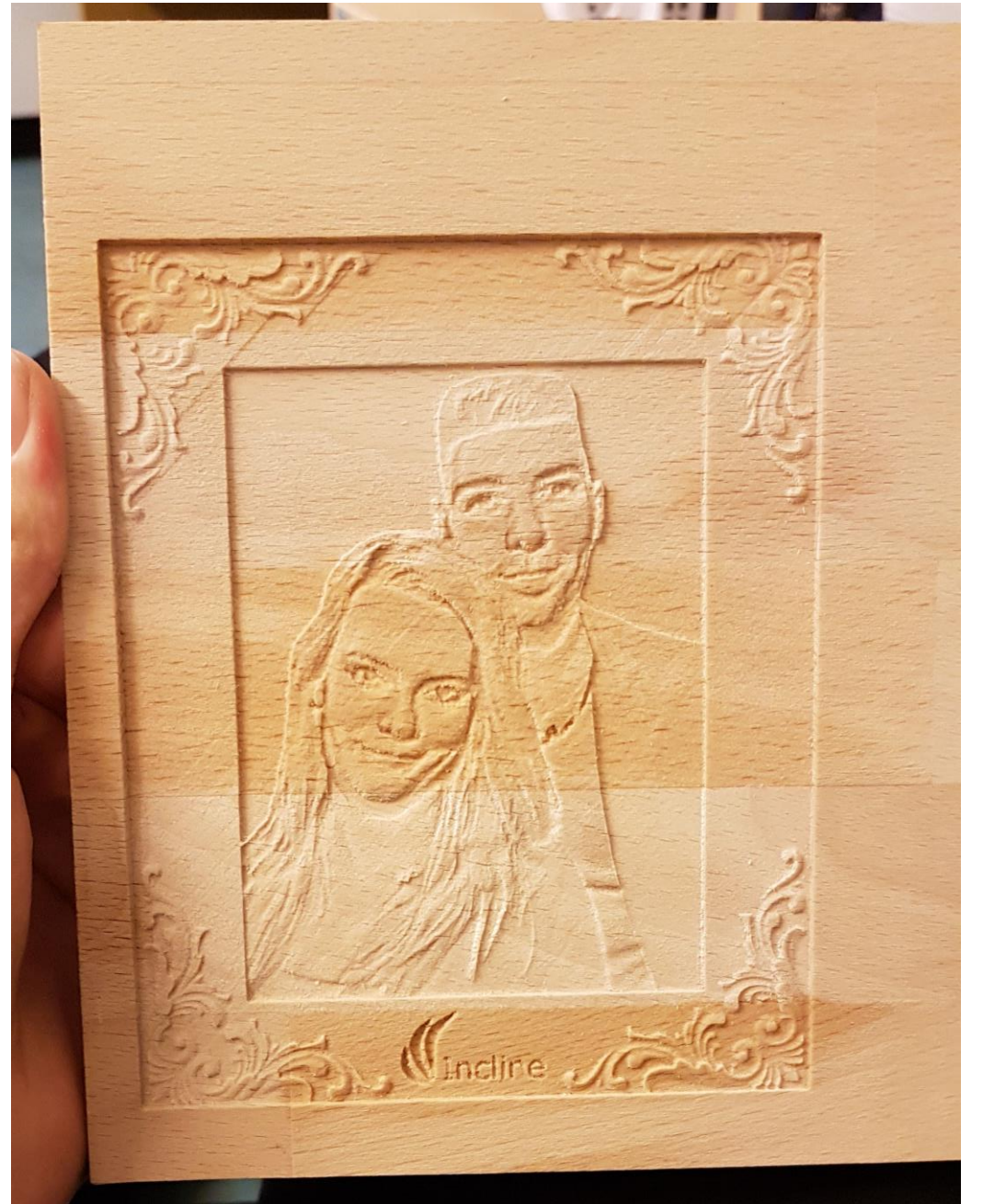

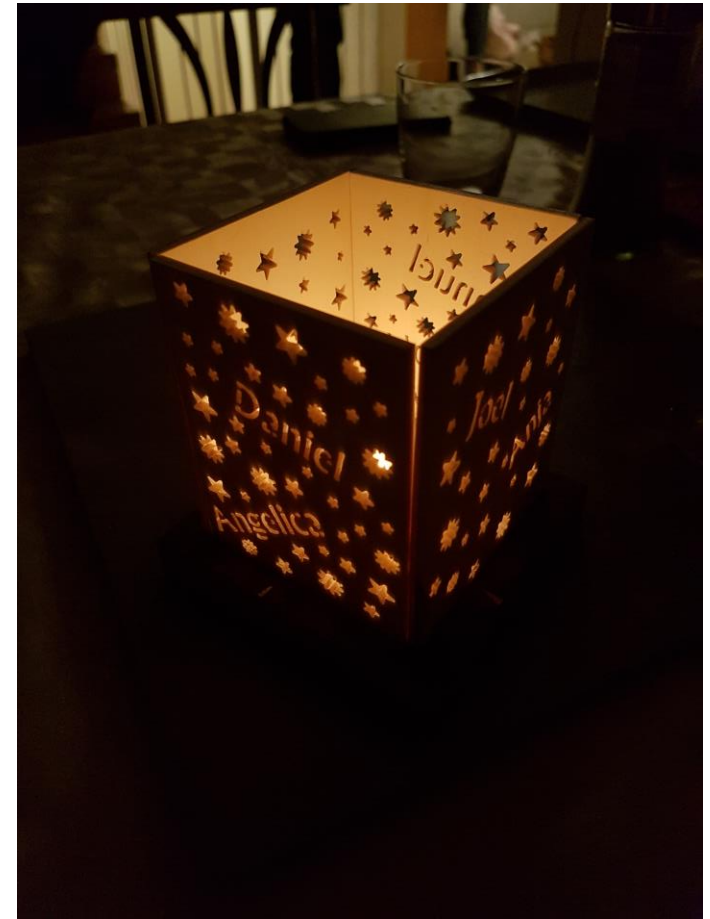
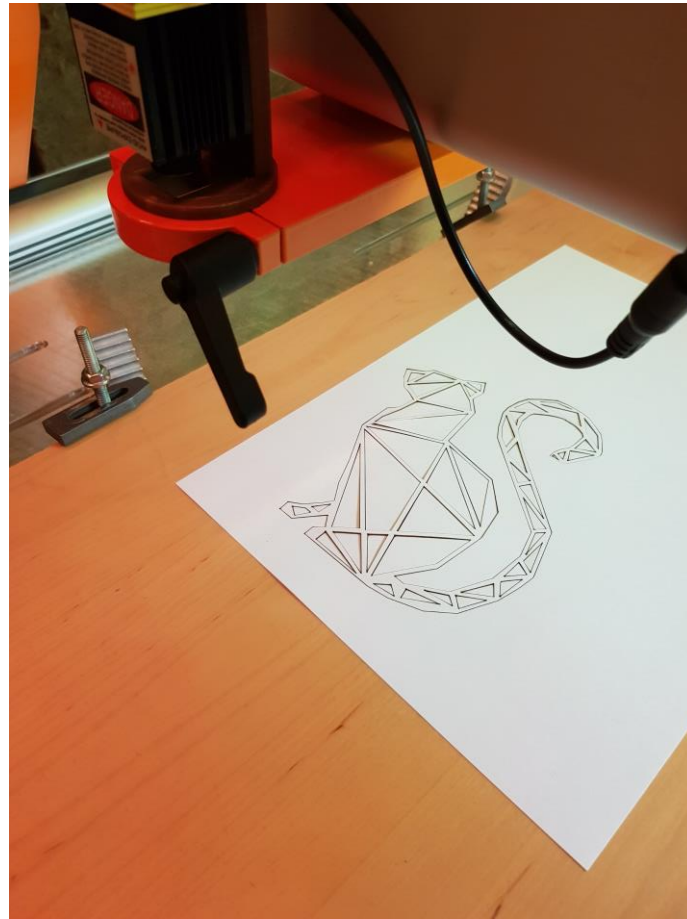

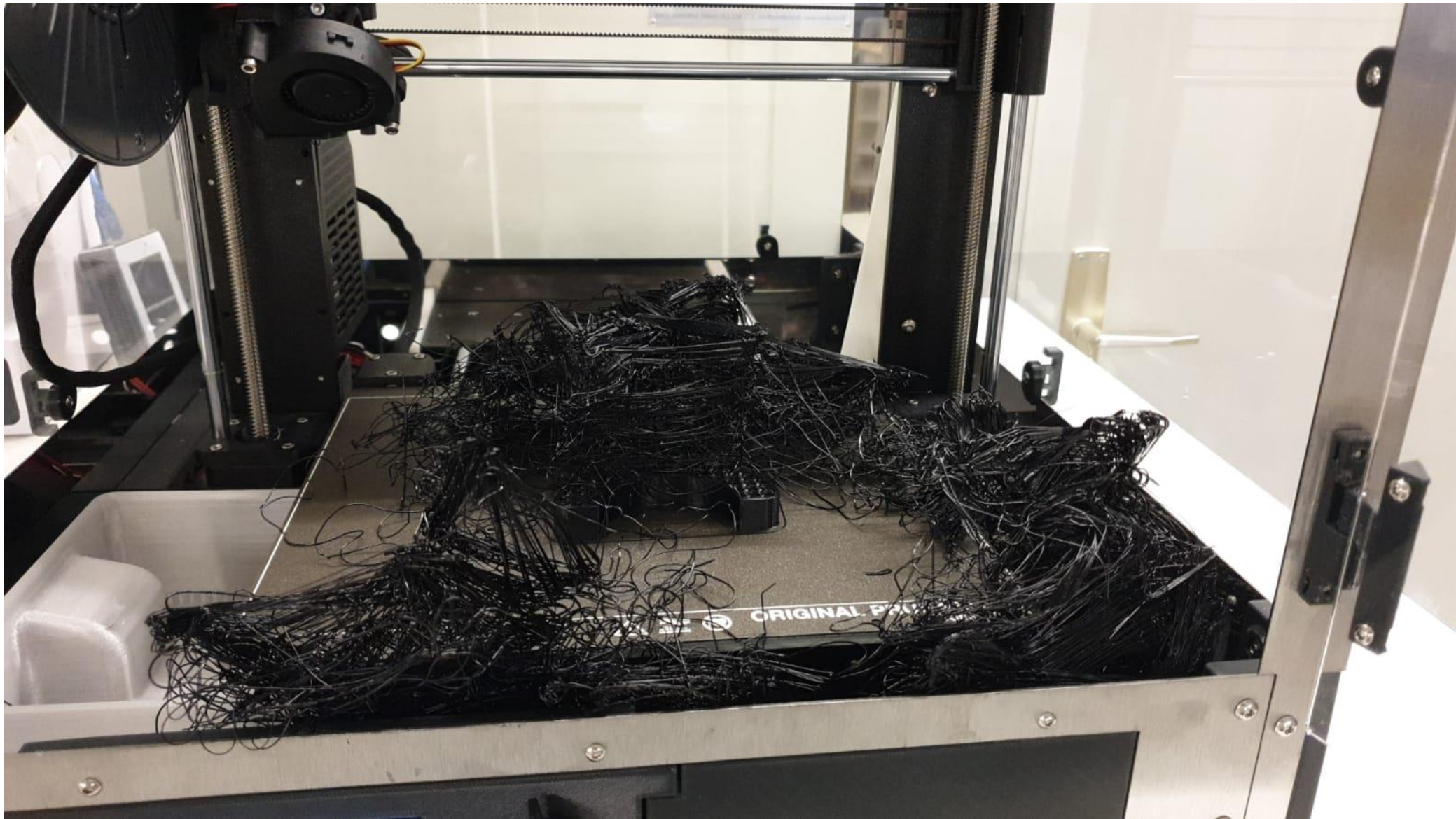

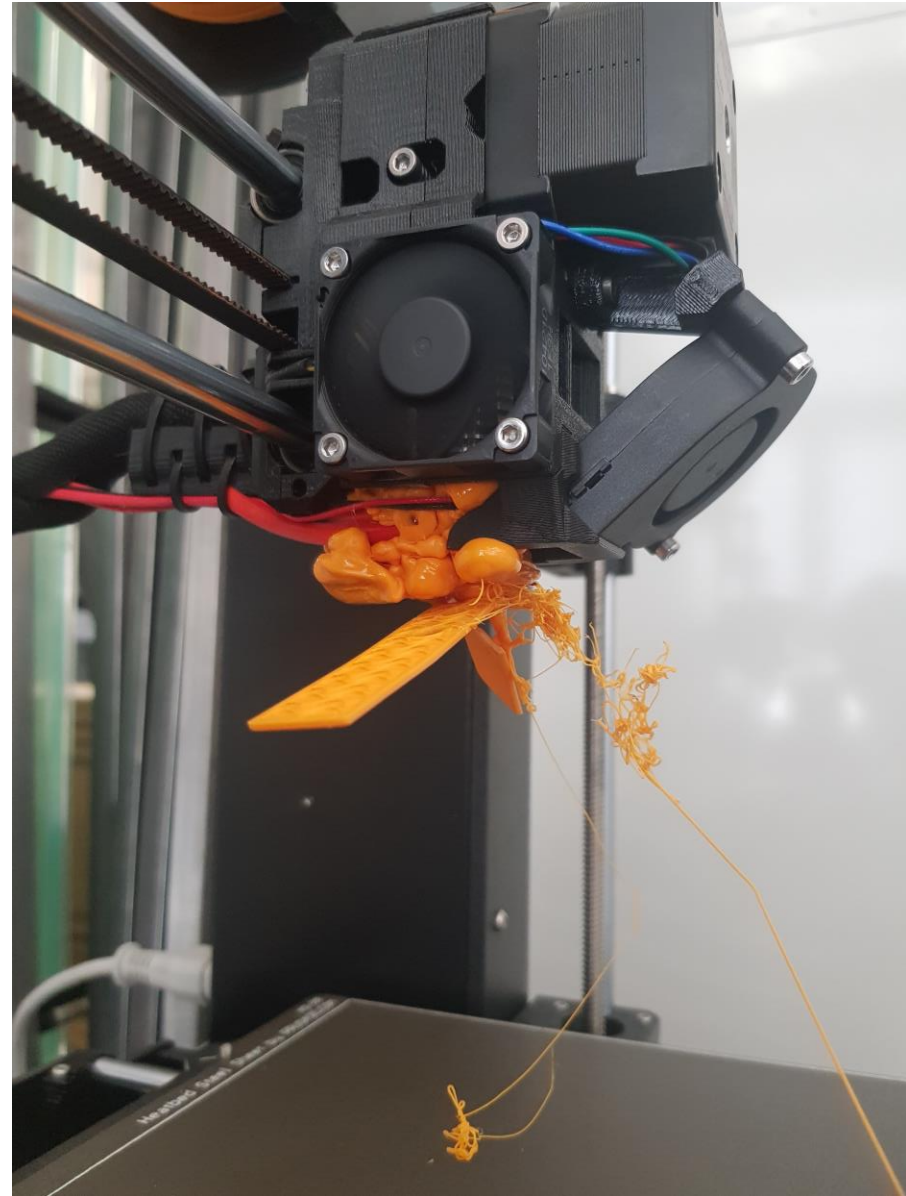

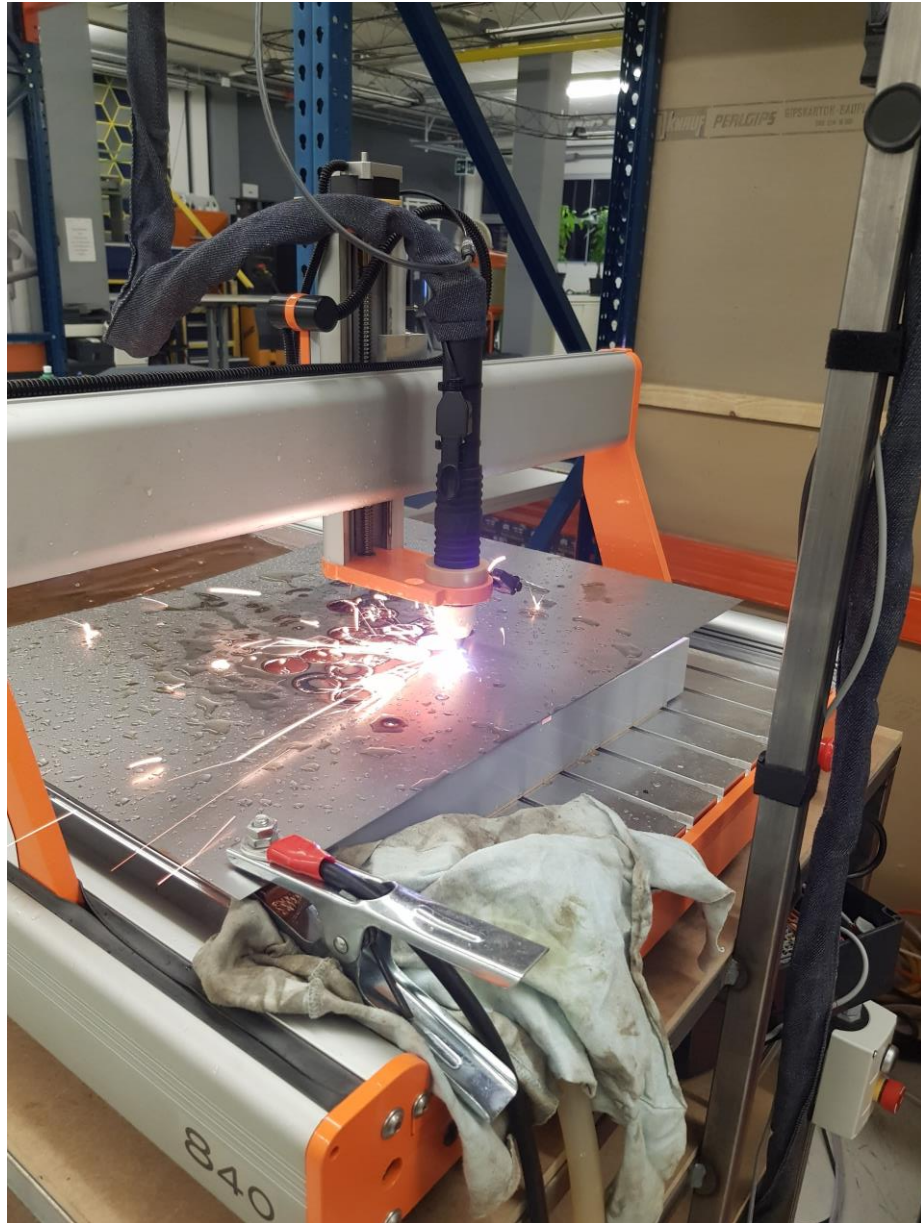

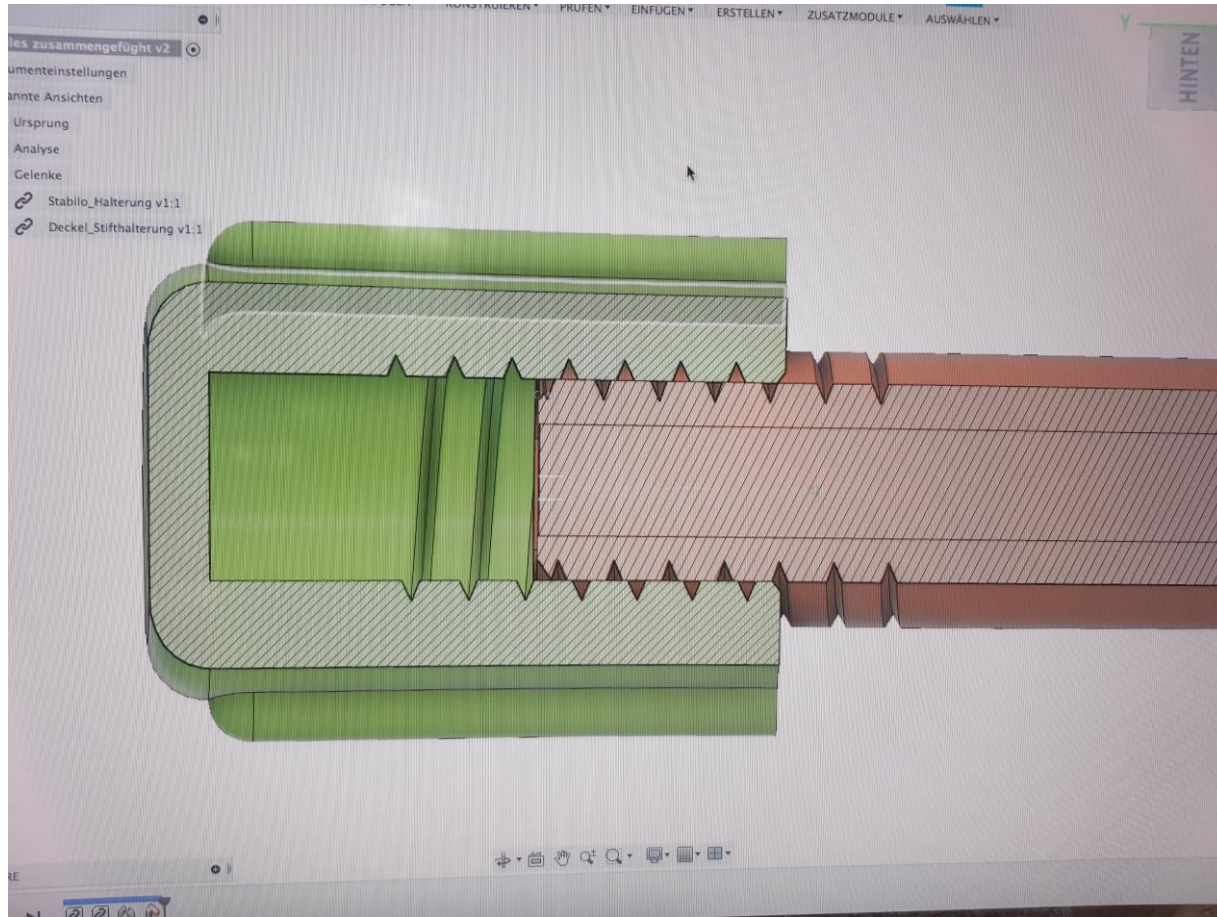

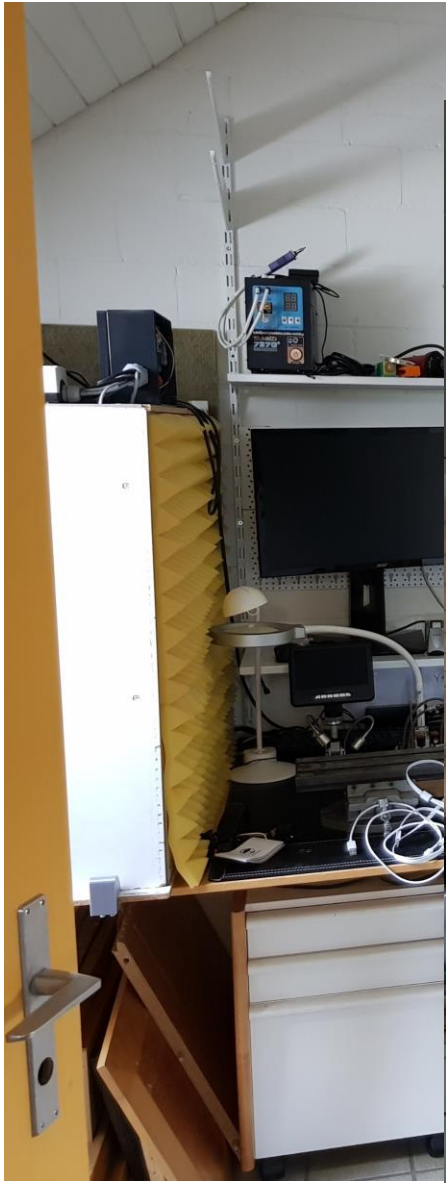

Was ist ein Fablab?

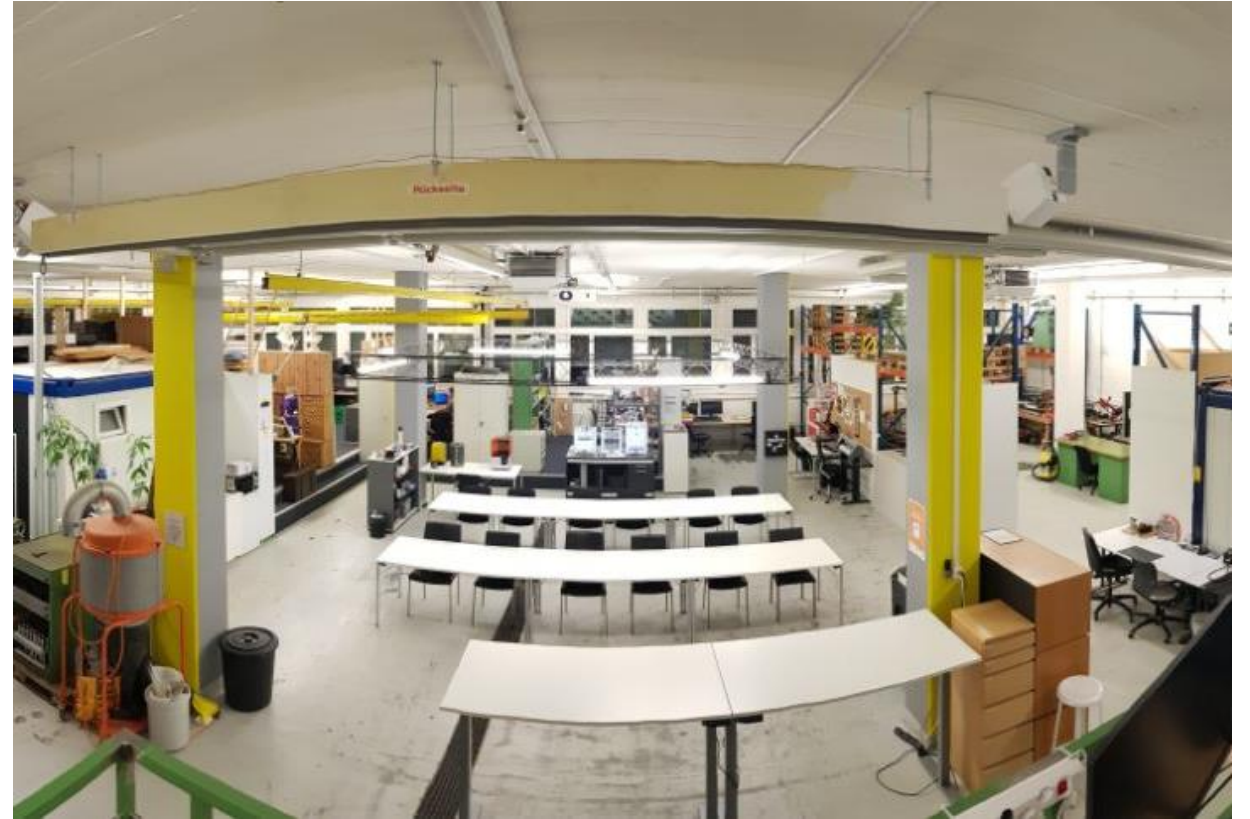

FabLab Zug - Maker Space

- Zugang zu Maschinen für alle
- Ein Ort der Begegnung
- Wissensaustausch
- Ideen verwirklichen



Maker Space FAB LAB ZUG DI, MI 18-21h
Maker werden SA 10-16h

Wir ermöglichen allen den Zugang zu Werkzeugen und digitalen Maschinen und fördern den Austausch von Wissen und Erfahrung. Ein Ort für Tüftler und Interessierte.

Über den Verein

[Home](#) [Makerspace](#) [Reservierung](#) [Verein](#)

Ausstattung

All 3D Drucker CNC Fräse Laser Cutter Schneideplotter

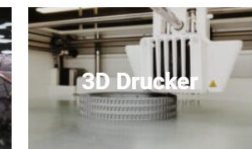
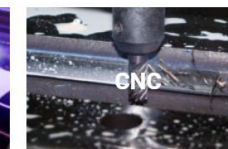

«Ein aktives, lokales Netzwerk ist Gold wert.»



Making im Kanton Zug

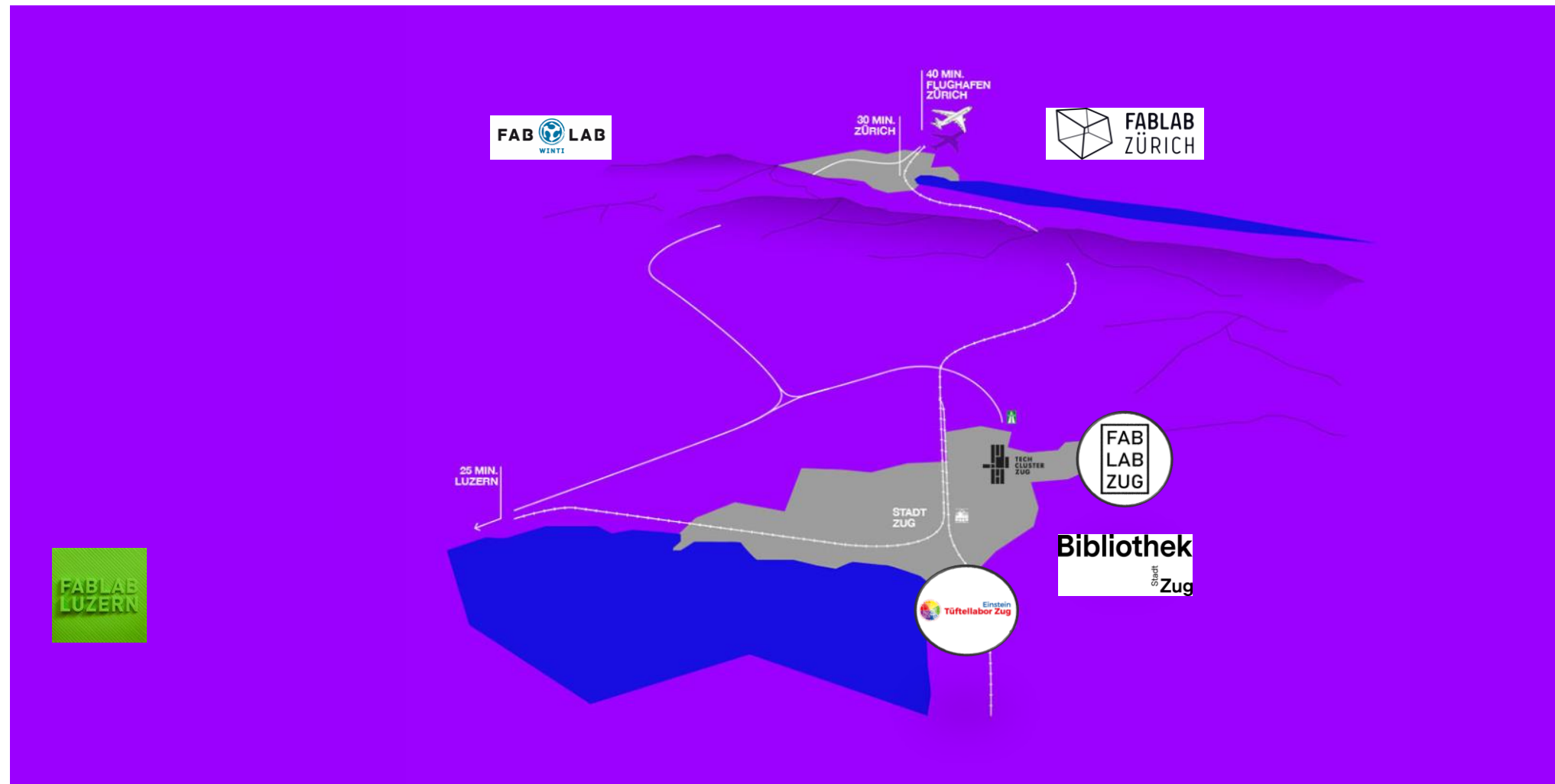



Einstein Tüftellabor Zug



<https://www.zentralplus.ch/>



<https://www.grenchnertagblatt.ch/>

Digiwerkstatt

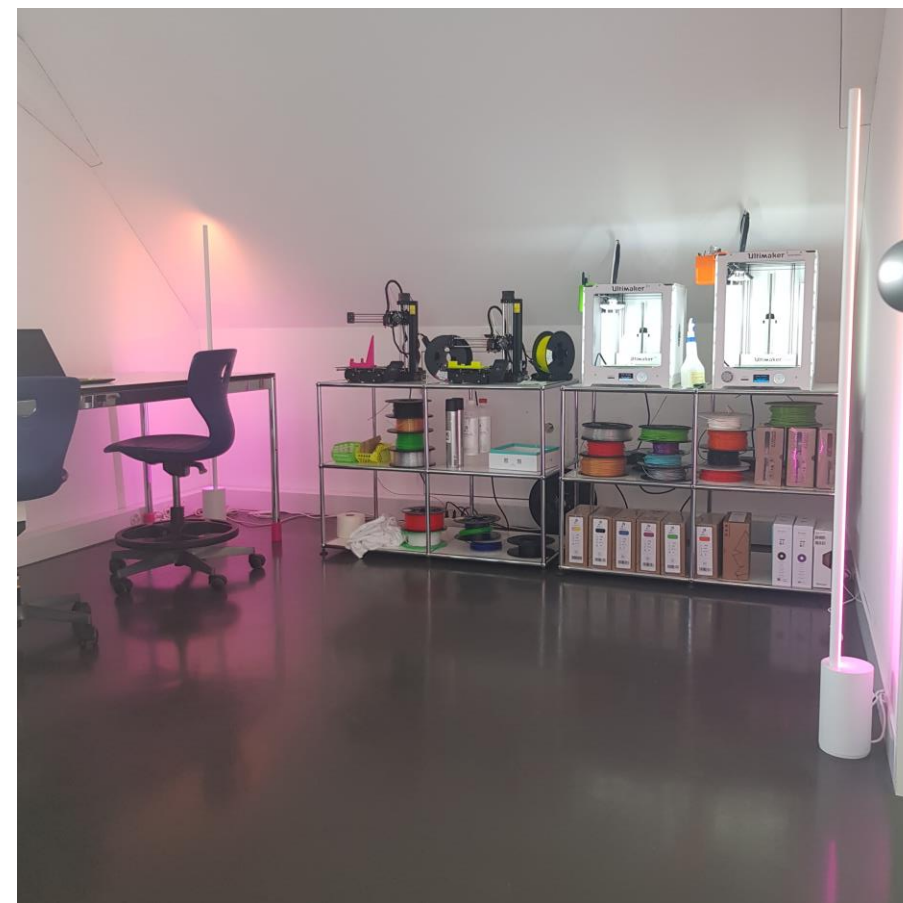
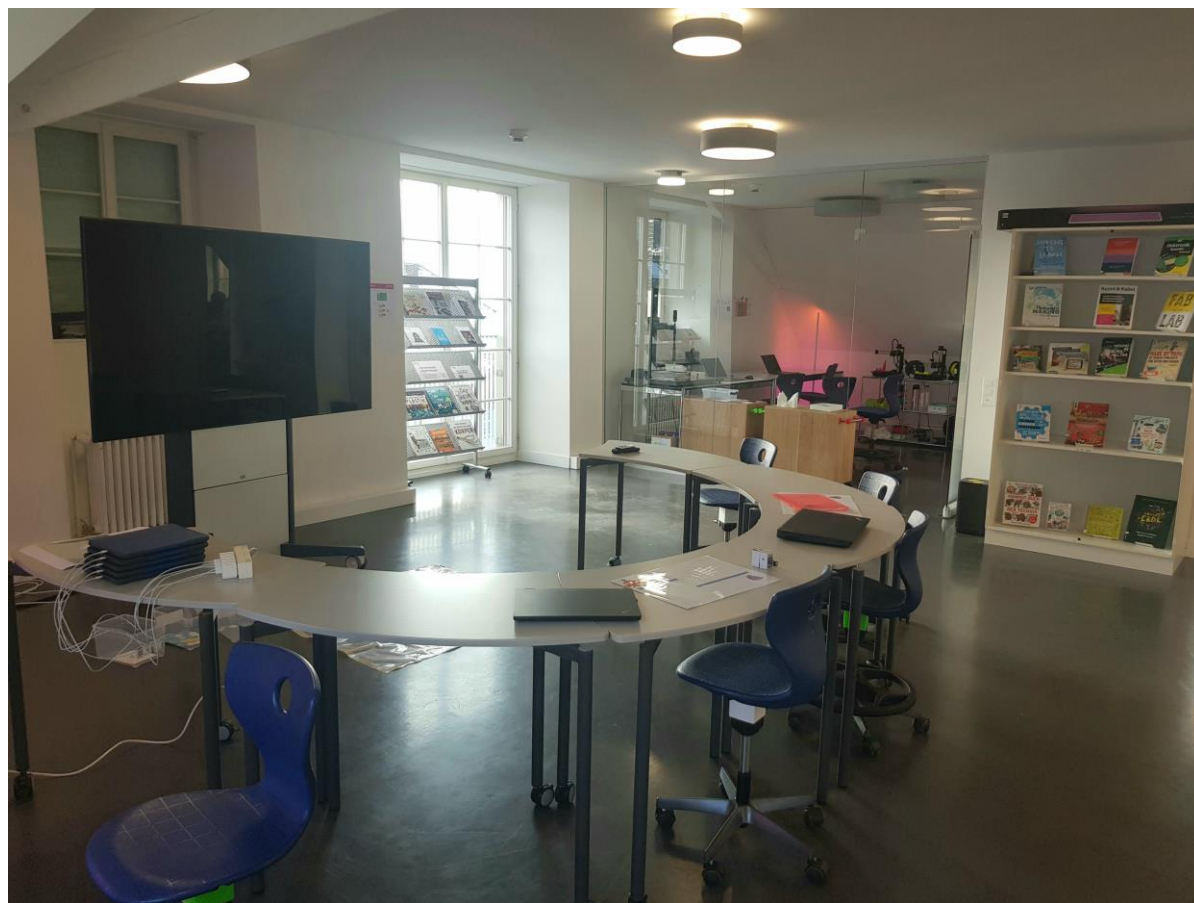

3D conference und Aussichten



Maker Faire 2024

- Was ist das?
- Wie könnte so was aussehen?



Tagesprogramm Samstag

	Grosser Saal	Foyer	Probebühne			Werk21 (im Keller)	Textil- werkstatt	Metall- werkstatt	Siebdruck- werkstatt	Medien- werkstatt	Projektraum (bei Medien)		
10:00	Ausstellung: 3D Druck, Computer, Cosplay, Elektronik, Internet of Things, Roboter, Steampunk	Ausstellung: Augmented Reality, Kunst- handwerk, Mechatronik	Ausstellung: Edtech, Upcycling Walk-in Workshops: Postapo- kalypti- scher Schmuck										
10:30													
11:00													
11:30													
12:00						Talks:							
12:30	Walk-in Workshops:					Open Education Plattform Openki							
13:00	Ätzen und Löten mit SGMK		UX Tipps und Tricks für Maker	Workshop: StepSynth Synthesizer Löten mit Flipfloater	Workshop: Minecraft Hacking	On Hackathons		Walk-in Workshop: Vibra Wire Bot	Walk-in Workshop: DIY T-Shirt Bedrucken	Workshop: Repeat- Patterning	Workshop: Indoor Windspiel mit Raspberry Pi		
13:30						DigitalSocial.eu							
14:00	Sand- strahlen mit Swiss FabLabs					Fake it till you make it	Workshop: Electronic Voodoo Doll						
14:30						Erfolg beim Crowdfunding							
15:00						Industrie- design 4.0							
15:30	Solar- Laterne mit Swiss FabLabs					FabLab World Tour							
16:00													
16:30						Badabum-Kids							
17:00				Workshop: Roboter für Kleinkinder									
17:30						Shapies Meetup							

